

*breath fresh*



Star  
series

Design For:



Bathroom



Kitchen



Living Area



Office



Room



## STAR - (B) / (I) / (W) / (G) 8

- ★ Removable front for easy cleaning
- ★ Design for glass, walls & false ceiling
- ★ Low noise level
- ★ High suction capacity
- ★ Low power consumption
- ★ ABS plastic body
- ★ Silicon steel lamination motor
- ★ Anti-Reflux Shutter
- ★ Fully copper winding motor
- ★ Motor is equipped with automatic thermal overload protection
- ★ B-Black / I-SS Finish / W-White / G - Grey

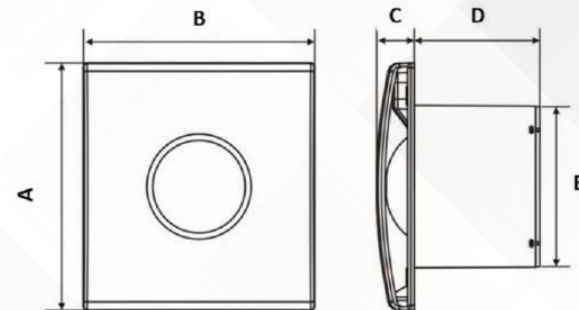

### Specifications

Models	A(mm)	B(mm)	C(mm)	D(mm)	E(mm)	Volts/Hz	Watts	Air-Flow (m <sup>3</sup> /hr)	Size
STAR (B)/ (I)/(W)/(G)-8	267	252	37	129	195	220-240/50	25	420	200